

CLASS

STANDARD

42 61
1950

July 11, 1950

M. H. WALKER ET AL

2,514,981

(3-10-50)

FIRING MECHANISM FOR FIREARMS

Filed Feb. 12, 1948

2 Sheets-Sheet 1

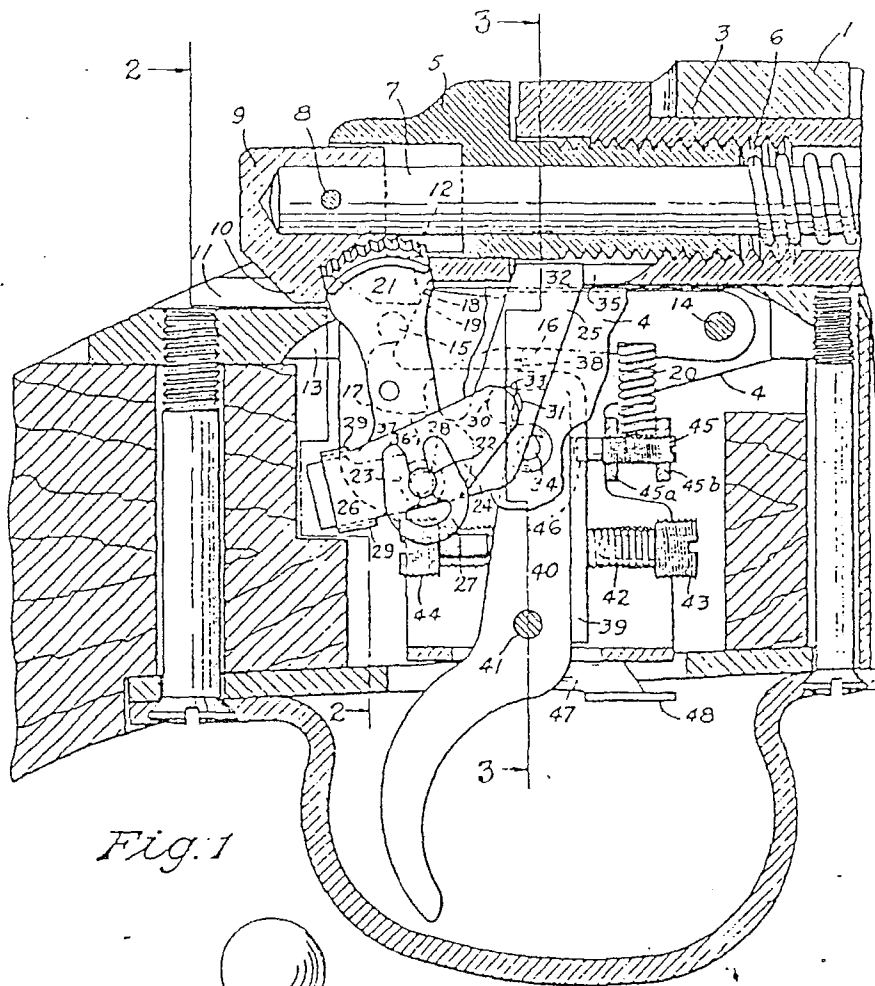

Fig. 1

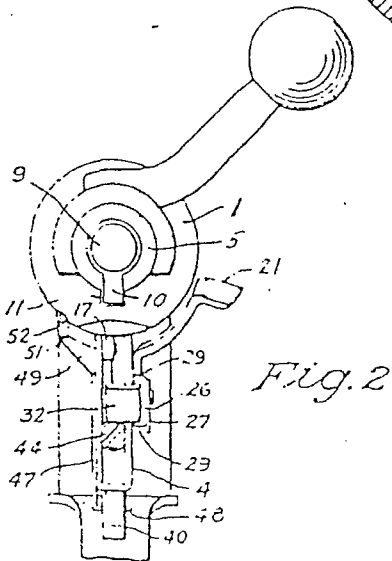

Fig. 2

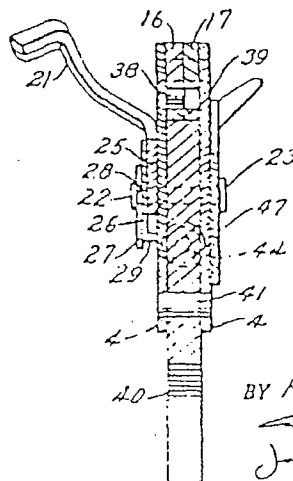

Fig. 6

INVENTORS
MERLE H. WALKER
BY PHILIP R. HASKELL

John H. Lewis Jr.

PLAINTIFF'S
EXHIBIT
220

July 11, 1950

M. H. WALKER ET AL
FIRING MECHANISM FOR FIREARMS

2,514,981

Filed Feb. 12, 1948

2 Sheets-Sheet 2

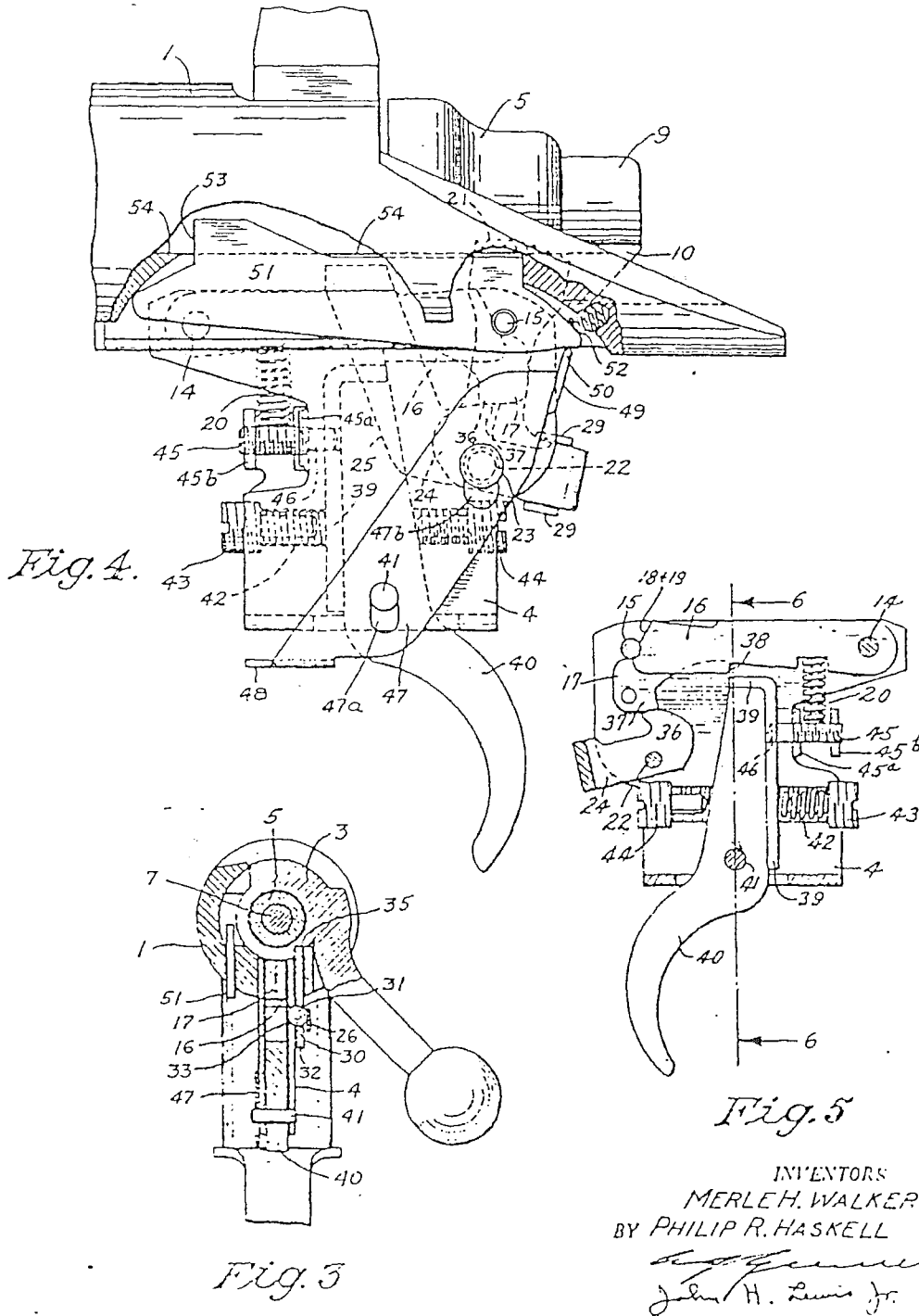

INVENTORS
 MERLE H. WALKER
 BY PHILIP R. HASKELL
John H. Lewis Jr.

UNITED STATES PATENT OFFICE

2,514,981

FIRING MECHANISM FOR FIREARMS

Merle H. Walker and Philip R. Haskell, Iion,
N. Y., assignors to Remington Arms Company,
Inc., Bridgeport, Conn., a corporation of Dela-
ware

Application February 12, 1948. Serial No. 7,778

5 Claims. (Cl. 42-~~800~~ 70)

1

This invention relates to firearms and has particular reference to means for controlling the firing thereof.

Many well-known firearms employ a breech closing bolt which has a reciprocating movement in opening and closing the breech and which may be locked in the closed position by any suitable means. Most of these firearms are provided with spring-urged bolt mounted strikers or firing pins and depend upon means relatively fixedly mounted in the receiver to engage the firing pin or an extension thereof to restrain it against forward movement and to insure trigger controlled release when such release is desired. It is to this type of firearm that our invention is particularly applicable.

A suitable fire control for a firearm of this type provides readily operable means for locking the firing pin positively in a "Safe" position as well as a trigger controlled sear to permit the instant release of the firing pin when it is desired to fire. The value of any safety is proportional to the positiveness of its action. To this end we have found it to be essential that the safety means be so arranged that an inadvertent operation of the trigger while the safety is in "Safe" position will not condition the arm to fire upon release of the safety. The value of any type of sear mechanism is proportional to the degree in which it provides for facile, clean, release free from the disturbing effects of drag, creep, or slap.

It is an object of our invention to provide a fire control having a safety which operates by positively moving the firing pin rearwardly out of contact with the sear and there releasably retaining it. In this way, should the trigger be operated while the safety is engaged, the trigger and sear springs will immediately reposition the mechanism to catch the firing pin upon release of the safety.

It is a further object of this invention to provide a sear and control therefor which operate on barely perceptible movement of the trigger, yet releases the firing pin instantly and completely.

It is contemplated that these objects may be best attained by mounting on the receiver a housing containing two similarly shaped members engageable with the firing pin in such a way that the firing pin energy urges the members to move out of opposition thereto. One of these members may be conveniently identified as a safety cam and the other as a sear. A safety piece arranged to move into contact with the safety cam and a trigger assembly arranged to releasably oppose disengaging movement of the sear, provide for controlling the movement of these members, and through them the firing pin is controlled.

The exact nature of the invention as well as

2

other objects and advantages thereof will become more clearly apparent from consideration of the specification referring to the accompanying drawings in which:

Figure 1 is a vertical, longitudinal sectional view of a portion of the assembled rifle action.

Figure 2 is a rear elevational view of the receiver and trigger housing assembly.

Figure 3 is a vertical, transverse sectional view on the line 3-3 of Fig. 1, the stock and trigger guard having been removed to correspond with Fig. 2.

Figure 4 is a partial left side elevational view of the receiver and trigger housing assembly.

Fig. 5 is a right side elevational view of the fire control assembly, the right-hand side plate and elements supported thereon having been removed for clarity in illustrating the interior construction.

Fig. 6 is a vertical sectional view taken on the line 6-6 of Fig. 5.

Referring to the drawings by characters of reference, it may be seen that the portion of a rifle action which is illustrated comprises a receiver 1 which serves as a housing for a conventional type of upturn and pull back bolt 3 and as a mounting for a trigger housing 4. In the usual fashion the rear end of the bolt is closed with a bolt plug 5 which serves as an abutment for the main spring 5 and as a guide for the firing pin 7. Secured on the rear end of the firing pin by a cross pin 8 is a firing pin head or cocking piece 9. The docking piece is formed with a rib 10 which is slidably received in a groove 11 in the receiver and with an angularly disposed sear engaging face 12.

A longitudinally extending mortise 13 is milled through the bottom wall of the receiver to accommodate the trigger housing 4 which is secured therein by cross pins 14 and 15 mounted in the receiver and passing through the trigger housing assembly to serve as pivots and stops for elements therein.

Between the side plates of the trigger housing which may be conveniently blanked and formed from a single piece of sheet metal, the front cross pin 14 pivotally supports the sear 16 and the safety cam 17. Each of these members occupies substantially half of the width between the side plates and in their top contour they are substantially identical. They are provided with similar striker engaging faces 18 and 19, the angular relationship between these striker engaging surfaces and the sear engaging face 12 being such that there is a tendency for sear and safety cam to swing counter-clockwise about the pivot pin 14 under the urging of the main spring 6 which acts through the firing pin 7. Such an angular relationship between the engage faces and the radius passing through the contact point is com-

monly known as a "negative angle" as distinguished from a "positive angle" where the force components act to retain the two surfaces in engagement. This tendency is slightly resisted by the sear spring 20 which engages both sear and safety cam with sufficient pressure to urge them to turn clockwise when they are free from the firing pin load until they are stopped by engagement with pin 15. Positive means to be next described are provided for absolutely preventing movement of sear and safety cam under main spring urging except when such movement is desirable.

A safety 21 is pivotally mounted on a pivot pin 22 which has an enlarged head 23 on the left outside wall of the trigger housing and passes therethrough to support the inner arm 24 of the safety between the side plates and the outer arm 25 outside the right hand wall. A leaf spring 26 is also received on the safety pivot pin and the assembly is held together by a wishbone key 27 engaged with an annular groove 28 in the pin. The rear end of the leaf spring is provided with inturned legs 29 which straddle the outer arm 25 and constrain the spring to turn with the safety. The forward or free end of the leaf spring overlaps a hole 30 in the bolt lock arm 32 of the safety. Loosely seated in the hole 30 is a ball detent 31 which is pressed into alternative engagement with detent holes 33 or 34 formed in the side wall of the trigger housing to releasably retain the safety in the desired position. It will be seen that the bolt lock arm 32 is in position to pass upwardly through the bottom wall of the receiver into engagement with a notch 35 in the bolt and lock same against rotation when the safety has been turned to its counterclockwise limit of rotation or "Safe" position. In the clockwise or "Firing" position, arm 32 does not extend through the receiver wall and the bolt may be readily turned to unlock the action.

Inner arm 24 of the safety is provided with an eccentric 36 which is disposed beneath the heel 37 of the safety cam. With the safety in "Firing" position, the eccentric does not engage the safety cam and release of the cocking piece by the sear will permit the safety to be cammed out of the way. However, when the safety has been rotated into "Safe" position the eccentric has engaged the heel of the safety cam and lifted it slightly. Since the safety cam engages the cocking piece on an angle, the effect of this upward movement will be to cam the cocking piece slightly to the rear. This rearward movement insures that the sear will be returned by the sear spring to position for full engagement with the cocking piece if the trigger should be inadvertently operated while the safety is effective.

As has been previously noted, the sear 16 is of the so-called "negative angle" type and under pressure of the main spring tends to rotate itself out of engagement with the cocking piece. The sear is supported against this disengaging force by engagement of the step 38 with the connector 39. Connector 39 is bent to substantially a right angle and lies against the front face and over the top of the trigger 40 which is pivotally mounted on a pin 41 passing through the side plates of the trigger housing 4. Trigger spring 42 seats against an adjustable screw 43 and bears on the forward face of the connector resiliently urging the connector into engagement with the trigger and through the connector,

resiliently urging the upper end of the trigger rearwardly. Movement of the trigger is limited in extent by an adjustable rear stop screw 44 which obviously limits the amount of engagement which the connector has with the sear step 38. Ordinarily, this latter adjustment will be made to a minimum safe value and the screw staked in place at the factory. Since the forces upon either screws 43 or 44 are not great, they may conveniently be of slightly greater diameter than the distance between the inside faces of the trigger housing 4 and have threaded engagement with an incomplete thread cut in those inside faces. Forward stop screw 45 serves as a convenient support for the sear spring 20 and passes freely through a hole 46 in the connector to oppose the trigger proper. To facilitate the support of the spring and to provide a rigid mounting, this screw may conveniently be mounted in threaded holes in brackets 45a and 45b turned inwardly from the side walls of the trigger housing 4. This stop screw provides an adjustment to positively stop trigger movement just as the sear is released and makes possible the complete elimination of undesirable trigger slap or overtravel. This complete elimination of trigger slap could not, however, be accomplished without endangering the crispness of the let-off if it were not for the flexible mounting of the connector, for it is not practicably possible to produce and maintain absolutely sharp square corners on the engaging surfaces of a sear and conventional trigger. Invariably after normal wear these corners will be rounded on a small radius which will permit the movement of the sear to start before the trigger has fully disengaged therefrom. If the sear is to completely release the striker a conventional trigger must have an overtravel or slap and the release will not be clean and crisp. If we examine the functioning of the unit, we will observe that the trigger and connector move as a unit until the instant the connector starts to clear the edge of the sear step. At this point the trigger stops but the connector is restrained only by the relatively light trigger spring 42 and, as the sear is cammed down, the radii existing on the points of the connector and sear cause the connector to be cammed forwardly and completely clear the sear step. This allows a clean crisp let-off closely approaching the target shooter's ideal without requiring any additional trigger movement after release is first instigated. These advantages of freedom from creep or slap with the short light trigger pull, crisp let-off, and short lock time characteristic of negative angle sears, have been achieved in a construction which is absolutely safe in the hands of the hunter or target shooter and rugged enough to remain so in spite of the abuse and neglect which are often heaped upon sporting arms.

It will be noted that clearance is provided in the lower face of the safety cam so that it cannot engage the connector and that the heel of the sear does not extend to a point where it can engage the safety eccentric. Thus, the operation of safety and sear is entirely independent in spite of their common mounting, common spring, and similar engagement with the cocking piece.

Mounted on the left hand side of the trigger housing is the bolt stop release 47 which has elongated slots 47a and 47b supported beneath the head 23 of the safety pivot pin 22 and on the left end of the trigger pivot pin 41. A finger

piece 48 extends into the trigger guard in position to be engaged by the finger for generally vertical movement and a lateral extension 49 at the upper end engages a notch 50 in the tail of the bolt stop 51. Preferably the slots 47a and 47b are disposed at an angle to each other so that the release has a combined translational and swinging movement, causing the extension 49 to follow closely the arcuate path of the notch 50. Support for the bolt stop is provided by the bolt stop pin 15 which, as previously noted, assists in retaining the trigger housing in assembled relation to the receiver. The bolt stop is resiliently urged to swing about the pin 15 in a clockwise direction, as viewed in Fig. 4, by a spring 52 seated in a blind hole in the receiver. Extending into the receiver under spring urging and withdrawable by the action of the shooter's finger on the fingerpiece 48 is the bolt stop shoulder 53. This shoulder normally extends a substantial distance into the usual type of guide track 54 for the left hand bolt locking lug and places a definite rearward limit upon movement of the bolt. Since the bolt stop release 47 is protected by the trigger guard from accidental contact with brush, a saddle scabbard or any other object which might dislodge an externally mounted bolt stop, it will be a practical impossibility to inadvertently pull the bolt free of the receiver.

Although a single specific embodiment has been illustrated and described in detail, it should be understood that the invention is not to be considered as limited to the exact embodiment disclosed. It is intended that all modifications and equivalents falling within the terms of the appended claims shall be considered as a part of the invention.

We claim:

1. Fire control means for a firearm having a spring urged striker comprising means defining a negative angle sear engaging face on said striker; a pivotally mounted sear having formed thereon a negative angle face arranged for engagement with the face of said striker; trigger means to releasably support said sear against disengagement from said striker as a result of striker spring force acting through said negative angle faces; sear spring means tending to restore said sear to striker engaging position; a pivotally mounted safety cam constructed and arranged to have negative angle engagement with said striker substantially similar to that of said sear; and manually actuatable safety operating means comprising an eccentric member manually rotatable about a fixed axis between a "Firing" position and a circumferentially displaced "Safe" position, said fixed axis being so disposed relative to said safety cam that said eccentric will not engage the safety cam in "Firing" position and in "Safe" position will have engaged said safety cam and shifted same into said further engagement with the striker.

2. Fire control means for a firearm having a receiver and a main spring-urged striker therein comprising an abutment on said striker having a sear engaging surface; a sear pivotally mounted in said receiver and engageable with said abutment surface, said sear being so arranged relative to said abutment that a line projected between the point of contact with said surface and the point of pivotal mounting of the sear makes an angle of greater than 90 degrees with said surface and a component of main spring force

acts to disengage the sear from said abutment; a lug on said sear; a trigger; means to pivotally support said trigger with a portion thereof beneath said lug; a connector overlying the portion of said trigger beneath said lug and carried thereby, said connector having an aperture therethrough and providing a surface releasably engageable with said lug; a trigger spring engaged with said connector arranged to act through said connector in opposing movement of said trigger; and trigger stop means passing through said aperture in position to limit movement of the trigger without retarding movement of said connector, said trigger and connector being so constructed and arranged that movement of the trigger into contact with said stop means will substantially complete the disengagement of said connector from said lug and further movement of the connector relative to the trigger will allow the sear to move without material impairment by said connector.

3. Fire control means for a firearm having a trigger housing and a sear which is acted upon by a force tending to release the sear comprising a lug on said sear; a trigger pivotally mounted in said housing having a surface movable into and out of a position opposed to said lug; a connector carried by the trigger and movable relative thereto, a portion of said connector overlying said surface and arranged to be engaged between said surface and said lug, said connector being arranged on said trigger to be moved thereby in the direction of disengagement from said lug and being also arranged to be capable of movement relative to said trigger in the direction of disengagement from said lug; spring means opposing movement of said connector relative to the trigger; and positive stop means on said housing arranged to block further movement of the trigger after the trigger has been moved to a position in which disengagement of said connector from said lug is substantially complete.

4. Fire control means as described in claim 3, said pivotally mounted trigger comprising an elongated member of which an end face forms said lug opposing surface; and said connector comprising an L-shaped member, one leg of which overlies said end face to be engaged with said lug while the other leg of said L-shaped member lies against said elongated member; said spring means being engaged between said other leg and said housing and tending to yieldingly hold said other leg in engagement with said elongated member.

5. Fire control means as described in claim 4, said L-shaped member being formed to provide an aperture through said other leg; said positive stop means comprising a screw adjustably mounted in said housing and passing loosely through said aperture in position to engage said elongated member when said trigger has been moved to said position in which disengagement is substantially complete.

MERLE H. WALKER.
PHILIP R. HASKELL.

REFERENCES CITED

The following references are of record in the file of this patent:

UNITED STATES PATENTS

| Number | Name | Date |
|-----------|----------|---------------|
| 1,425,808 | Thompson | Aug. 15, 1922 |
| 2,386,205 | Garand | Oct. 9, 1945 |